

FLOAT AND THERMOSTATIC STEAM TRAPS

Twin Float Traps DN 80 DN 100

FLT22S/TW – Carbon steel / FLT22SS/TW – Stainless steel

DESCRIPTION

FLT22/TW float and thermostatic (integral air vent) steam traps series are designed for all types of low and high pressure steam heating and process equipment.

Typical applications include unit heaters, heat exchangers, driers, jacketed vessels and all the applications where continuous drainage is essential.

Connections are flanged for horizontal application.

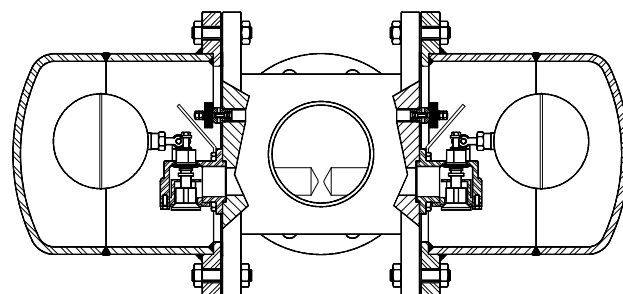
MAIN FEATURES

Modulating discharge.

Discharges condensate at steam temperature.

Unaffected by sudden or wide load and pressure changes.

Excellent air discharge (by thermostatic air vent).

USE: Saturated and superheated steam.

AVAILABLE

MODELS: FLT 22S/TW – Carbon steel
FLT22SS/TW – Stainless steel

SIZES: DN 80 – DN 100

CONNECTIONS: Flanged EN 1092-1 PN40 or ANSI

INSTALLATION: Horizontal standard installation.

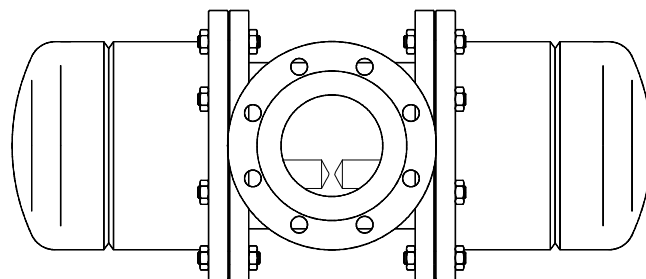

BODY LIMITING CONDITIONS				
FLT22S/TW		FLT22SS/TW		RELATED TEMP.
FLANGED PN 25 / ANSI 300 *	FLANGED ANSI 150 **	FLANGED PN 25 / ANSI 300 *	FLANGED ANSI 150 **	
ALLOW. PRES.	ALLOW. PRES.	ALLOW. PRES.	ALLOW. PRES.	
23,2 bar	15,4 bar	21,5 bar	15,7 bar	100 °C
20,8 bar	13,8 bar	17,5 bar	13,2 bar	200 °C
19 bar	12,1 bar	16,3 bar	12 bar	250 °C
17,2 bar	10,2 bar	15,1 bar	10,2 bar	300 °C

PMO - Max. operating pressure 14 bar TMO - Max. operating temperature 198 °C

* According to EN1092-1:2007 ; ** Acc. to EN1759-1:2004

Body limiting conditions PN25 or below, depending on the type of connection adopted. Rating PN25 for thread.

MAX. DIFFERENTIAL PRESSURE

FLT22S/TW-4,5 : 4,5 bar

FLT22S/TW-10 : 10 bar

FLT22S/TW-14: 14 bar

FLT22S/TW-21: 21 bar

Note: the same figures are valid for the FLT22SS/TW

CE MARKING (PED - European Directive 97/23/EC)		
PN 16	PN 25	Category
DN80 - DN100	--	1 (CE Marked)
--	DN80 - DN100	2 (CE Marked)

FLOW RATE CAPACITY IN Kgs/h												
MODEL	SIZE	DIFFERENTIAL PRESSURE (bar)										
		0,5	0,7	1	1,5	2	4,5	7	10	14	16	21
FLT22S/TW-4,5	80-100	15100	18100	22000	28000	31000	45000					
FLT22S/TW-10	80-100	7800	8900	10000	12200	14200	20000	27500	32000			
FLT22S/TW-14	80-100	3800	4600	5400	6200	7200	10000	13800	16200	19600		
FLT22S/TW-21	80-100	3800	4600	5400	6200	7200	10000	13800	16200	19600	20000	24100

Note: the same figures are valid for the FLT22SS/TW

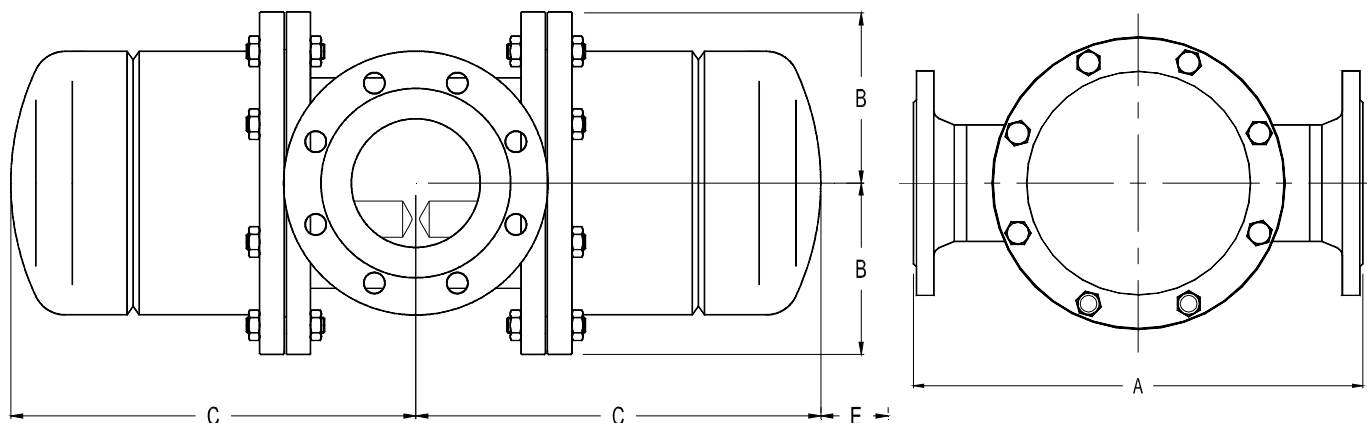

DIMENSIONS (mm)																
FLANGED EN 1092-1						FLANGE ANSI B16.5 Cl.150 lbs					FLANGE ANSI B16.5 Cl.300 lbs					
SIZE DN	A	B	C	E	WGT. Kgs	A	B	C	E	WGT. Kgs	A	B	C	E	WGT. Kgs	
80 - 3"	440	155	312	200	71,9	440	155	312	200	76	440	155	312	200	79	
100 - 4"	440	155	312	200	73,8	440	155	312	200	79	440	155	312	200	81	

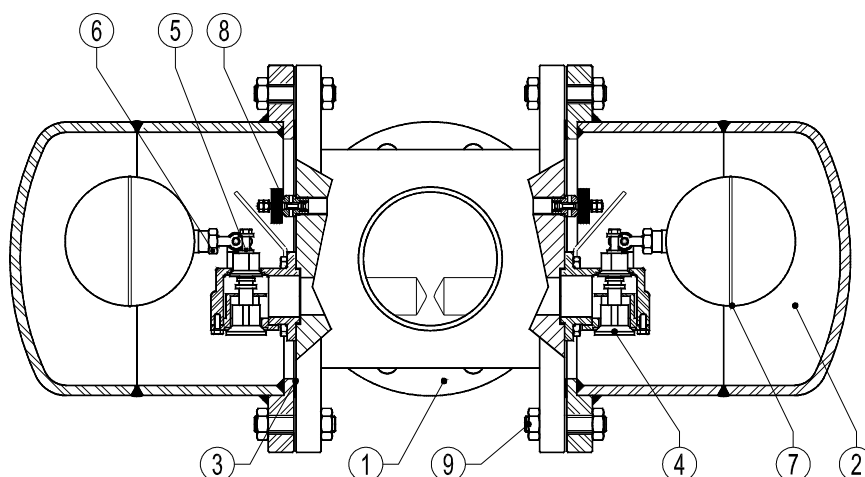

MATERIALS			
POS.Nr.	DESIGNATION	MATERIAL FLT22S/TW	MATERIAL FLT22SS/TW
1	Body	P250GH / 1.0460 ; P235GH / 1.0305 ; S355J2G3 / 1.0570 ; S235JRG2/1.0038	AISI316 / 1.4401 ; AISI304 / 1.4301
2	Cover	P235GH / 1.0305 ; P265GH / 1.0425 ; S355J2G3 / 1.0570	AISI316 / 1.4401 ; AISI304 / 1.4301
3	*Gasket	Graphite	Graphite
4	*Seat	CF8 / 1.4308	CF8 / 1.4308
5	*Valve	AISI420 / 1.4021	AISI420 / 1.4021
6	*Lever	AISI304 / 1.4301	AISI304 / 1.4301
7	*Float	AISI304 / 1.4301	AISI304 / 1.4301
8	*Air vent	Stainless steel (Bimetalic)	Stainless steel (Bimetalic)
9	Bolts	Steel 8.8	St. Steel A2-70

*Available spare parts.